



Tower USER MANUAL

HV Battery System
Tower -T7/T10/T14/T17/T21
192 - 576V

Contents

Statement of Law	1
Safety handling of lithium batteries Guide	2
1 Introduction	4
Brief Introduction	4
Product Properties	4
Product Identity Definition	4
Designation in the Document	6
2 Product Specification	7
System Performance Parameter	7
Battery Module	9
Battery Controller	11
3 Installation and Configuration	15
Environmental Requirement	15
Installation Clearance Requirements	16
Installation Location Precautions	16
Tools	16
Safety Gear	17
Unpacking inspection	17
Equipment installation	19
4 Maintenance	23
Trouble Shooting	23
Replacement of main component	24
Battery Maintenance	24
5 Storage Recommendations	26
6 Shipment	26

Statement of Law

Copyright of this document belongs to Dyness Digital Energy Technology Co., LTD. No part of this documentation could be excerpted, reproduced, translated, annotated or duplicated in any form or by any means without the prior written authorization of Dyness Digital Energy Technology Co., LTD.

This product complies with the design requirements of environmental protection and personal safety. The storage, use and disposal of the products shall be carried out in accordance with the product manual, relevant contract or relevant laws and regulations. Customers can check the related information on the website of Daqin New Energy Tech (Taizhou) Co., Ltd. when the product or technology is updated.

Web URL:<http://www.dyness-tech.com/>

Please note that the product can be modified without prior notification.

Revision History

Revision NO.	Revision Date	Revision Reason
1.0	2019.09.11	First Published
2.0	2020.03.03	Structural design changed
3.0	2020.06.28	Parameter changed
3.1	2020.09.28	<ol style="list-style-type: none"> 1. Changed the connector of the power cable 2. Changed the color of Power wake button 3. Added a negative output point and a module positive point on composite plug of module, add a negative output point and a module negative point on composite socket of module. 4. Added a positive output point and a negative output point on the composite socket of BDU. 5. Updated battery nameplate and module label
3.2	2021.03.02	<ol style="list-style-type: none"> 1. Updated the System Performance Parameter 2. Updated Installation clearance requirements 3. Updated Installation location precautions 4. Updated the Grounding.
3.3	2021.03.15	Upgraded adaptive function
3.4	2022.06.10	Updated the website

Safety Handling Guide of Lithium Batteries



DANGER

Before installation or operation you must read <Tower ESS User Manual> carefully.
Battery strings will produce high voltage DC power and might cause a lethal voltage and electric shock.
Only qualified person can perform the wiring of the battery strings.



WARNING

This product is a high voltage DC system, could be operated by authorized person only.
Risk of battery system damage or personal injury.
DO NOT pull out the connectors while the system is running!
Keep all power sources off and verify that there is no voltage.
Battery damage may result in electrolyte leakage. If the electrolyte is leaked, do not touch the leaked electrolyte or volatile gas, and contact the after-sales service team for help immediately. If you touched the leaking material accidentally, please follow the steps below:

- Inhalation of leaking material: Evacuate from contaminated area and seek medical assistance immediately.
- Eye contact: Flush with clean water for at least 15 minutes and seek medical assistance immediately.
- Skin contact: Wash the contact area thoroughly with soap and clean water and seek medical assistance immediately.
- Ingestion: Induce vomiting and seek immediate medical assistance.
- Do not move the battery system if it is connected with an external expansion module.

If you need to replace or add a battery, please contact the after-sale service center.



CAUTION

Risk of battery system failure or life cycle reduction.

Before Connecting

Please check product and packing list first after unpacking, if product is damaged or lack of parts, please contact with the local retailer;

Before installation, make sure that the grid power is cut off and the battery is in the turned-off mode;

Do not mistake the positive and negative cables and ensure there are no short circuit connection to the external device;

It is prohibited to connect the battery to AC power directly;

Battery system must be well grounded and the resistance must be less than 1Ω

Please ensure that the electrical parameters of battery system are compatible with related equipment;

Keep the battery away from water and fire.

In Using

If the battery system needs to be moved or repaired, the power must be cut off and ensure that the battery is completely turned off;

It is prohibited to connect the battery with different types of battery.

It is prohibited to connect the battery with inverters that is compatible or with faulty;

It is prohibited to disassemble the battery (to avoid warranty tab be removed or damaged);

In case of fire, only dry powder fire extinguisher can be used, liquid fire extinguishers are prohibited;

Please do not open, repair or disassemble the battery except Dyness staffs or authorized personnel. We do not undertake any consequence or related responsibility which is caused by violation of safety operation or equipment safety standards.

Maintenance

Please read the user manual carefully (in the accessories);

If the battery is stored for a long time, it is required to charge them every six months, and the SOC should be no less than 80%;

Battery needs to be recharged within 12 hours, after fully discharged;

Do not expose cable outside;

All the battery terminals must be disconnected for maintenance;

Please contact the supplier within 24 hours if there is something abnormal.

The warranty claims are excluded for direct or indirect damage due to items above.

1 Introduction

Brief Introduction





Tower is a high voltage battery energy storage system based on lithium iron phosphate battery, and it's one of the new products developed and produced by Dyness. It can be used to provide reliable power for various types of equipment and system. Tower is especially suitable for application scene of high power, limited installation space, restricted load-bearing and long cycle life.



Product Properties

- The whole module is non-toxic, non-polluting and environment-friendly;
- Anode material is made from LiFePO4 with high security and long cycle life;
- Battery management system (BMS) has protection functions including over-discharge, over-charge, over-current and high/low temperature;
- The system can automatically manage charging and discharging state and balance current and voltage of each cell;
- Flexible configuration, multiple battery modules can be in series for expanding voltage and capacity.
- Adopted self-cooling mode rapidly can rapidly reduce system noise;
- The module has less self-consumption, does not need be charged up to 6 months; no memory effect, excellent performance of shallow charging and discharging;
- Working temperature range is from 0 to 50°C, with excellent discharging performance and cycle life;
- Small size and light weight, standard module is easy for installation and maintenance;

Symbol Definition

DYNESS ENERGY STORAGE SYSTEM					
	T7	T10	T14	T17	T21
Nominal Energy/kWh	7.1	10.7	14.2	17.8	21.3
Nominal Voltage/V	192	288	384	480	576
Nominal Capacity/Ah	37	37	37	37	37
Ambient Temp/°C	0~50	0~50	0~50	0~50	0~50
IP Grade	54	54	54	54	54
Protective Class	I	I	I	I	I

















WWW.DYNESS-TECH.COM
DAQIN NEW ENERGY TECH (TAIZHOU) CO.,LTD

Figure 1-1 Battery Energy Storage System Nameplate

Table 1-1 Symbol Definition

	Battery voltage is higher than safe voltage. Be careful of electric shock.
	Be careful with your actions and be aware of the dangers.
	Read the user manual before using.
	The scrapped battery cannot be put into the garbage directly can and must be recycled by professional personnel or institutes.
	At the end of battery life, the battery can continue to be used after being recycled by professional recycling organization. Please do not discard it at will.
	This product meets European directive requirements.
	This product passed the TUV certification test.



Product Name: **HV9637**

Module: **LFP Lithium Ion Battery**

Capacity/Voltage: **37Ah/96V**



Total Storing Energy: **3.552kWh**

Charge Voltage: **105~108V**

Max. Discharge Power: **3.5kW**

Series Number:

Manufacture Date:

www.dyness-tech.com

DAQIN NEW ENERGY TECH(TAIZHOU) CO.,LTD

Figure 1-2 Battery Module Label

Abbreviations in the Document

Table 1-2 Abbreviations in the Document

Abbreviations in this Document	Full Name
BDU	Battery Disconnect Unit
BMS	Battery Management System
SOC	State Of Charge
PCS	Battery Module Quantity
DOD	Depth of discharge
NC	Normally Closed

2 Product Specifications

System Performance Parameter

Table 2-1 The Parameter of Tower System

Model	T21	T17	T14	T10	T7
Cell Technology	LFP	LFP	LFP	LFP	LFP
Total Storing Energy [kWh]	21.31	17.76	14.21	10.66	7.10
Usable Energy [kWh]	21.31	17.76	14.21	10.66	7.10
Recommend Depth of Discharge	80%	80%	80%	80%	80%
Max Depth of Discharge	100%	100%	100%	100%	100%
Module configuration	6 Series	5 Series	4 Series	3 Series	2 Series
Voltage Range[Vdc]	504~657	420~547	336~438	252~328	168~219
Battery System Voltage (Vdc)	576	480	384	288	192
Battery System Capacity (Ah)	37	37	37	37	37
Battery System Charge Voltage (Vdc)	657	547.5	438	328.5	219
Battery System Charge Current [A] (Standard)	7.4	7.4	7.4	7.4	7.4
Battery System Charge Current [A] (Normal)	18.5	18.5	18.5	18.5	18.5
Battery System Charge Current [A] (Max)	37	37	37	37	37
Battery System Discharge lower-Voltage (Vdc)	504	420	336	252	168
Battery System Discharge Current [A] (Standard)	7.4	7.4	7.4	7.4	7.4

Model	T21	T17	T14	T10	T7
Battery System Discharge Current [A] (Normal)	18.5	18.5	18.5	18.5	18.5
Battery System Discharge Current [A] (Max)	37	37	37	37	37
Battery System Max. Charge& Discharge Current [A] (in communication with the inverter)	22.5	22.5	22.5	22.5	22.5
Discharge Temperature Condition [°C]	-10~50	-10~50	-10~50	-10~50	-10~50
Charge Temperature Condition [°C]	0~50	0~50	0~50	0~50	0~50
Max. Discharge Power [kW]	21.31	17.76	14.21	10.66	7.1
Max. Charge& Discharge Power [kW] (in communication with the inverter)	12.78	10.65	8.52	6.39	4.2
Short Circuit Current [kA]	1.5	1.5	1.5	1.5	1.5
IP Grade	IP54	IP54	IP54	IP54	IP54
Size [mm]	504*1500*380	504*1300*380	504*1100*380	504*900*380	504*700*380
Weight [kg]	269	228	187	146	105
Battery Module Name	HV9637	HV9637	HV9637	HV9637	HV9637
Battery Module Quantity(pcs)	6	5	4	3	2

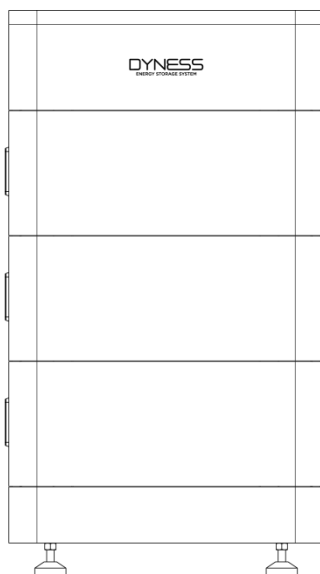

Figure 2-1 Tower T10

Battery Module

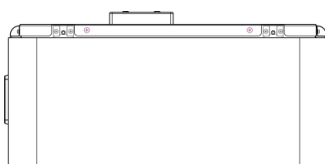

Figure 2-2 Battery Module

Table 2-2 Product Parameters

Module Name	HV9637
Cell Technology	Li-ion(LFP)
Battery Module Energy (kWh)	3.552
Battery Module Voltage (Vdc)	96
Battery Module Capacity (Ah)	37
Battery Module Cell Quantity (pcs)	30
Battery Cell Power (Wh)	118.4
Battery Cell Voltage (Vdc)	3.2
Battery Cell Capacity (Ah)	37
Battery Module Cell Quantity in Series (pcs)	30
Battery Module Charge Voltage (Vdc)	109.5
Battery Module Charge Current (Normal) [A]	18.5
Battery Module Charge Current (Max.) [A]	37
Battery Module Discharge lower-Voltage (Vdc)	84
Battery System Discharge Current (Standard) [A]	7.4

Module Name	HV9637
Battery Module Charge Current (Normal) [A]	18.5
Battery Module Charge Current (Max.) [A]	37
Dimension (W*D*H, mm)	380*504*240
Communication mode	CAN
Pollution Degree (PD)	II
Working Temperature(°C)	0~50
IP Grade	IP54
Weight(kg)	41

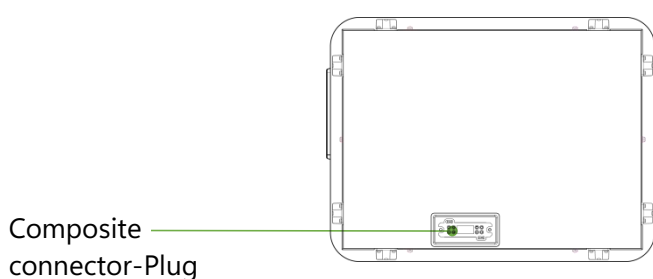

Figure 2-3 HV9637 Top Interface

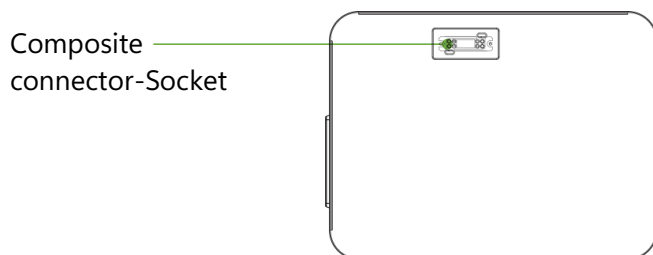

Figure 2-4 HV9637 Bottom Interface

Table 2-3 Interface Definition

Name	Definition
Composite connector-Plug	Battery module output and communication interface
Composite connector-Socket	Battery module output and communication interface

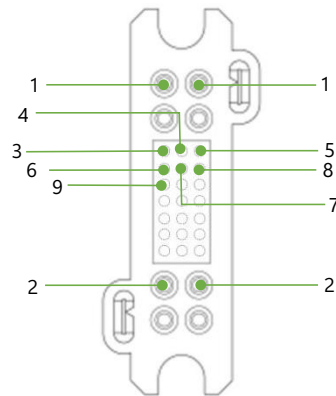

Figure 2-5 Composite Connector-Plug

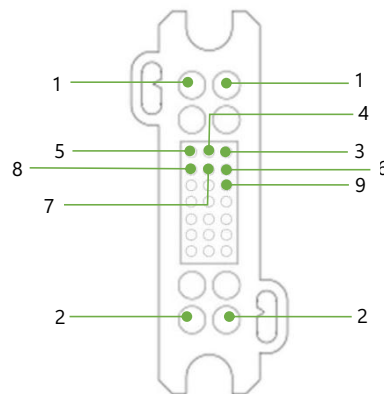

Figure 2-6 Composite Connector-Socket

Table 2-4 Port Definition

NO	Composite Connector-plug	Composite Connector-socket
1	Negative output	Negative output
2	Module positive	Module positive
3	SWAKE	SWAKE
4	SCANSG	SCANSG
5	SCANL	SCANL
6	SCANH	SCANH
7	24V-	24V-
8	24V+	24V+
9	SCANIN	SCANOUT

Battery Controller

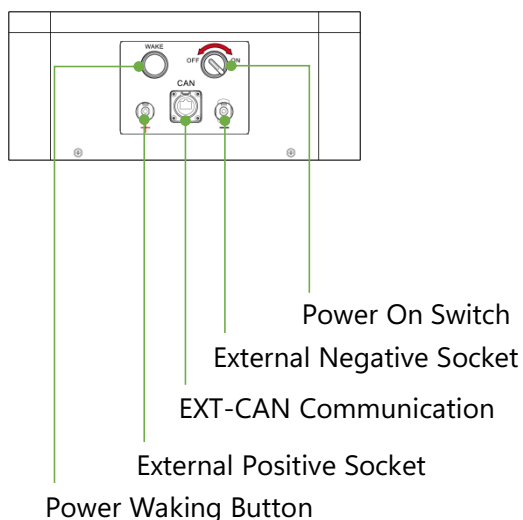

Figure 2-7 BDU Right Interface

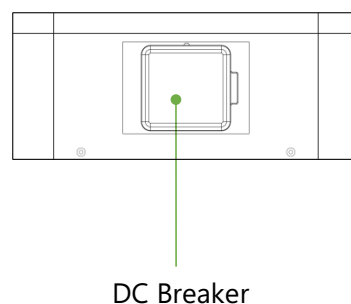

Figure 2-8 BDU Left Interface

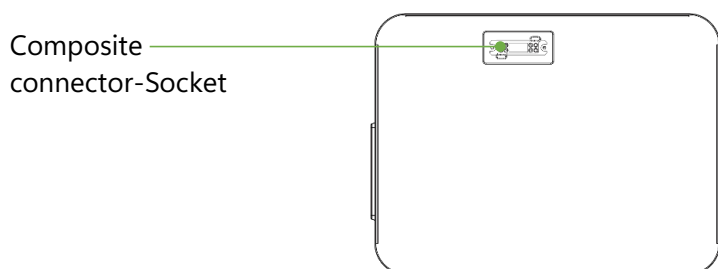

Figure 2-9 BDU Bottom Interface

Table 2-5 Interface Definition

Name	Description
Power Wake Button	Long press this button 5secs to start the battery system
External Positive Socket	Connect battery system with Inverter positive terminal
EXT-CAN Communication Port	RJ45 communication port between the battery system and inverter
External Negative Socket	Connect battery system with Inverter negative terminal
Power On Switch	Turn on the switch to power the BMS system
DC Breaker	The master switch of the battery system, you must switch on it before switching on power on&power wake button; Short circuit protection.
Composite Connector-Socket	Battery module output and communication interface

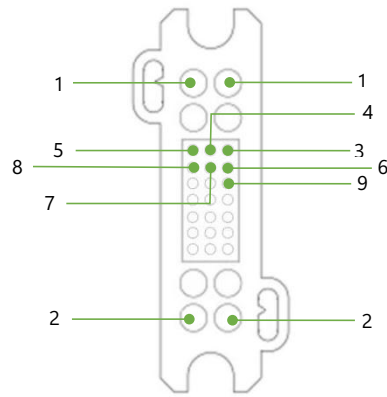

Figure 2-10 Power On Switch

**CAUTION**

Generally when it is at ON state, you can't turn off it during normal running condition.

Table 2-6 Port Definition

NO	Definition
1	Negative Output
2	Positive Output
3	SWAKE
4	SCANSG
5	SCANL
6	SCANH
7	24V-
8	24V+
9	SCANOUT

**DANGER**

Ensure Power On Switch is turned on before waking up the battery. Otherwise it will affect automatic checking process and cause danger.

DO NOT turn off the "Power On Switch" during normal running condition, only in emergency case it could be turned off directly. Otherwise it will cause this battery string current surged by another battery strings.

CAUTION

When the DC breaker tripped off because of over current or short circuit, must wait for 30mins to turn on it again, otherwise it may cause the breaker damage.

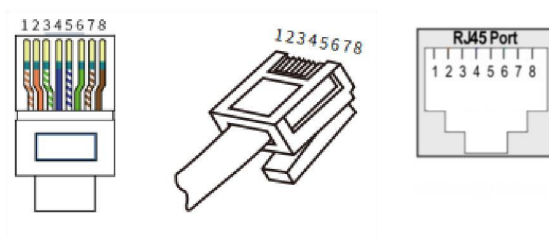

Figure 2-11 "EXT-CAN" Port Pin

Table 2-7 Definition of "EXT-CAN" Port Pin

PIN	Color	Definition
PIN1	Orange/White	Reserved
PIN2	Orange	XGND
PIN3	Green/White	Reserved
PIN4	Blue	CANH
PIN5	Blue/White	CANL
PIN6	Green	NC
PIN7	Brown/White	Reserved
PIN8	Brown	NC

3 Installation and Configuration

Environmental Requirement



DANGER

Cleanliness

The battery system has high voltage connectors. The environment condition will affect the isolation performance of the system.

Before installation and powering on, the dust and iron scurf must be removed to keep environment clean. And the environment must have certain dust-proof ability.

Dust and humidity condition shall be regularly checked during continuous operation of the system.

Fire-extinguisher System

The room must be equipped with fire-extinguisher system for safety (Recommended: foam extinguisher). The fire-protection system needs to be regularly checked to ensure it is in normal condition. Please refer to your local fire protection equipment for use and maintenance requirements.

Grounding System

Make sure that the grounding point for battery system is stable and reliable before installation. If the battery system is installed in an independent equipment cabin (e.g. container), must make sure that the grounding of the cabin is stable and reliable.

The resistance of the grounding system must $\leq 100\text{m}\Omega$



CAUTION

Temperature

Tower system working temperature range: $0^{\circ}\text{C}\sim 50^{\circ}\text{C}$; Optimum temperature: $18^{\circ}\text{C}\sim 30^{\circ}\text{C}$; Exceeding the working temperature range will cause overtemperature/ undertemperature alarms or protection of the battery system which may lead to the cycle life reduction.

Cooling System

It is essential to equip a cooling system to keep the battery system in a relevant temperature range. overtemperature/ undertemperature alarms or protection of the battery system which may lead to the cycle life reduction.

Heating System

It is essential to equip a heating system to keep the battery system in a relevant temperature range. If the environment is lower than 0°C , the system may be shut down for protection. It is necessary to open the heating system at first. Out of the working temperature range will cause the battery system over / low temperature alarm or protection which may lead to the cycle life reduction.

Installation Clearance Requirements

! DANGER

Please note that the battery should be installed with a minimum safe clearance from the surrounding equipment or battery. Please refer to the minimum clearance diagram below.

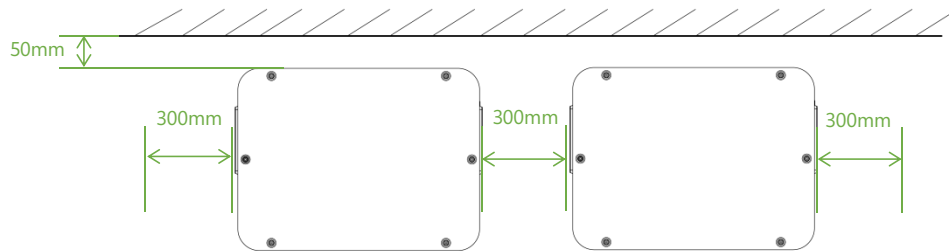

Figure 3-1 The Minimum Clearance Diagram

Installation Location Precautions

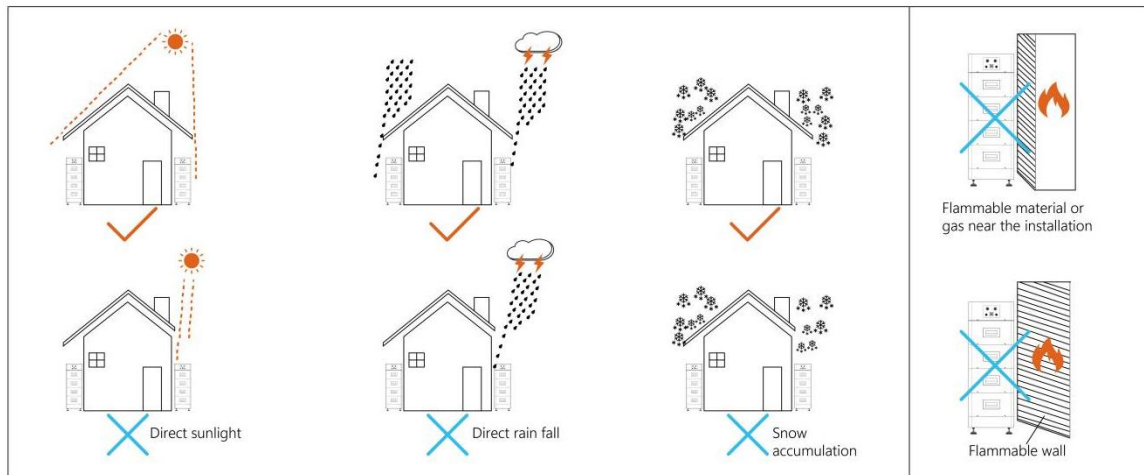

Figure 3-2 Installation Location Precautions

Tools

The following tools are required to install the battery pack:

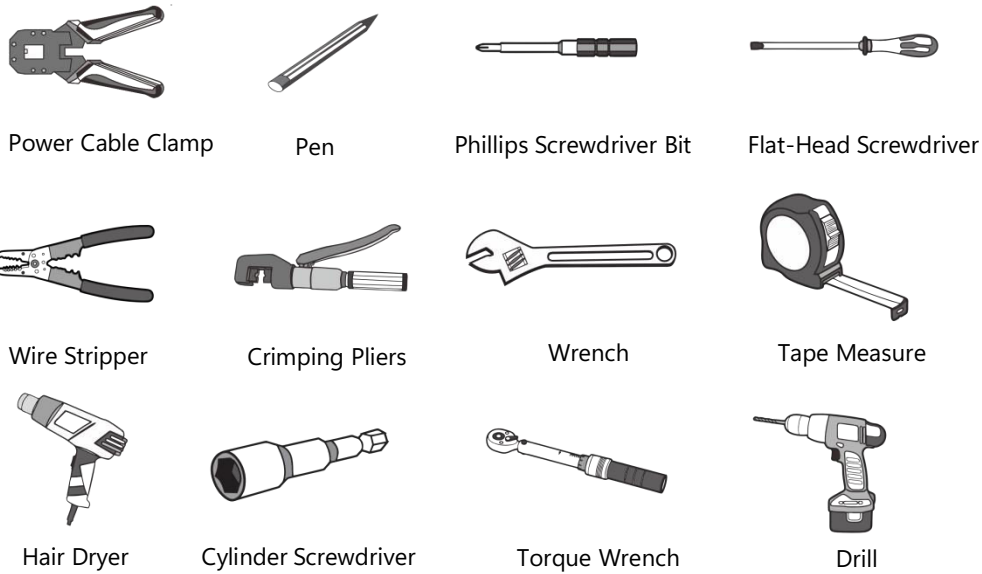

Figure 3-3 Installation Tools

CAUTION

Use properly insulated tools to prevent accidental electric shock or short circuits. If insulated tools are not available, cover the entire exposed metal surfaces with available insulated alternatives, and their tips need to be covered with electrical tape.

Safety Gear

It is recommended to wear the following safety gear when dealing with the battery pack



Figure 3-4 Safety Gear

Unpacking Inspection







When the battery system arrives at the installation site, loading and unloading should be performed according to the rules and regulations, to prevent from being exposed under sunlight. Battery should not be installed in locations under direct sunlight. Please refer to P16 Figure 3-2 Installation location precautions.



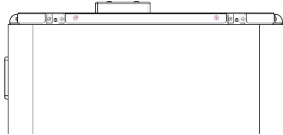
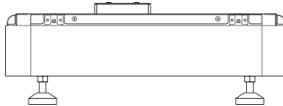

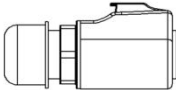
Before unpacking, the total number of packages shall be counted according to the shipping list attached to each package, and the case should be checked for good condition.

In the process of unpacking, handle carefully and protect the surface coating of the object.

After opening the package, the installer should read the technical documents, verify the list, ensure that the objects are complete and intact according to the configuration table and packing list, and if there is damage to the internal packaging, it should be checked and recorded in detail.

Table 3-1 Packing List

Item	Specification	Quantity	Figure
Tower BDU	504*380*156.5mm	1 PCS	
Battery Module HV9637	96V/37Ah 504*380*240mm	4 PCS	
Tower Base	504*380*186mm	1 PCS	
Communication Cable to Inverter	Standard, Black /L2000mm /RJ45 plug at both sides	1 PCS	
Communication Connector to BDU	RJ45 Waterproof connector	1 PCS	
Cross Recessed Countersunk Head Screw	M4*10	20 PCS	
M6 3 Sets of Combined Screws	M6*14	1 PCS	
Terminal	OT4-6	2 PCS	
User Manual	30Page	1 PCS	

Power Cable Connector	To positive pole of battery	1 PCS	
Power Cable Connector	To negative pole of battery	1PCS	
Power Cable	Positive cable 6mm ² ,red,2m	1 PCS	
Power Cable	Negative cable 6mm ² ,black,2m	1PCS	

Equipment Installation

Installation preparation

1. Make sure that the environment meets all technical requirement.
2. Prepare equipment and tools for installation.
3. Confirm that the DC breaker is in the OFF state to ensure that it is no live operation.

Mechanical installation

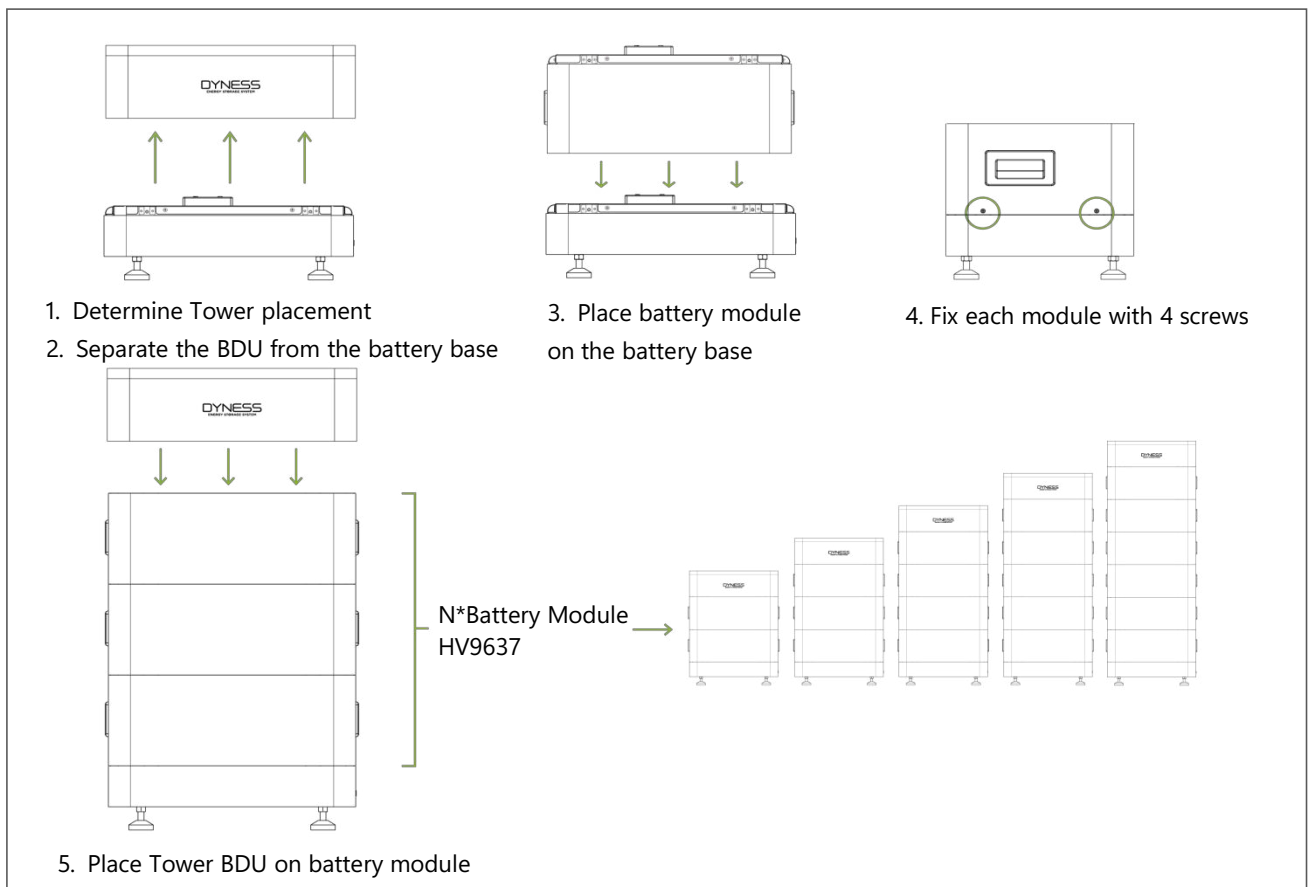

Figure 3-5 Mechanical Installation

**DANGER**

The battery system is high voltage DC system. Must make sure that grounding surface of the Tower is stable and reliable.

Please confirm that the battery system is in the off state before connect. It maybe cause electric shock to personnel and damage to the inverter if connect the battery directly without power off.

Otherwise, the system cannot work properly. The voltage of the battery is too high, please pay attention to self-protection during the measurement.

**WARNING**

Single battery module is 41kg. It's necessary to arrange more than 1 person to install battery module if without lifting equipment, more than 2 persons when installing battery module in higher position.

Double check all the power cables and communication cables. Make sure that the voltage of the inverter is in the same level as the battery system.

- Switch on the inverter, to make sure that all the power equipment can work normally.
- Start the battery system. Referring to P20 Table 3-2 Battery system self-test Step 2.

Table 3-2 Battery System Self-test

Step1 Electrical installation

Battery system grounding

(After the HV9637 module is stacked up and down, it is fixed by two screws on the left and right sides. After the screw is fixed, the shell surface of the upper and lower modules are fixed and contacted together through screws. There is a special docking point at the bottom of the battery base. As shown on the right)

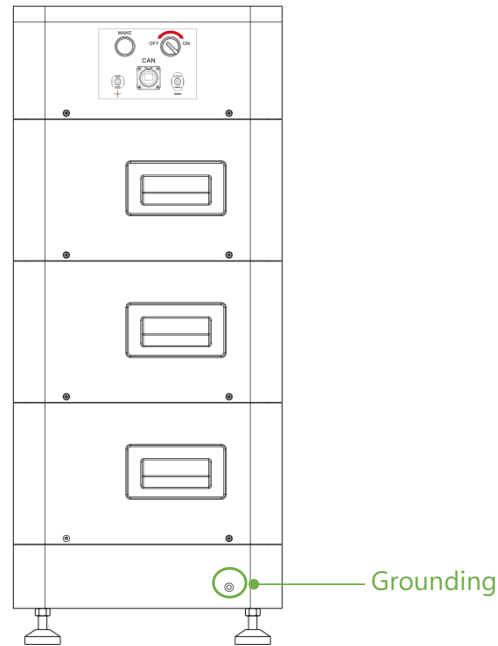

Step2 Battery system self-test

1. Switch on the DC breaker of the BDU

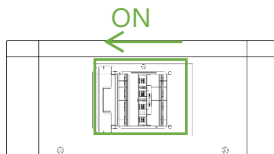

2. Switch on the "POWER ON" switch

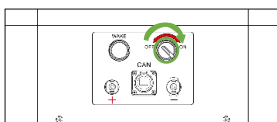

3. Press the "POWER WAKE" button for about 5secs



4. Check the system output voltage
 - Use a multimeter to measure the output voltage on the positive and negative ports of the BDU
 - The output voltage should conform to the voltage range in the table "P7 Table 2-1 The parameter of Tower system".
5. Switch off the "POWER ON" switch.

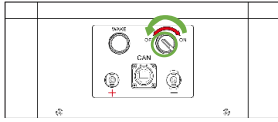

6. Switch the BDU "DC BREAKER" to the "OFF" state.

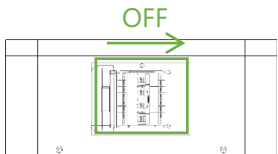

Step3 Connecting inverter

1. Connect External Power Cable to the inverter
(If that 2m power cable is not long enough, please find another power cable of the same specification, the length cannot be longer than 3m.)

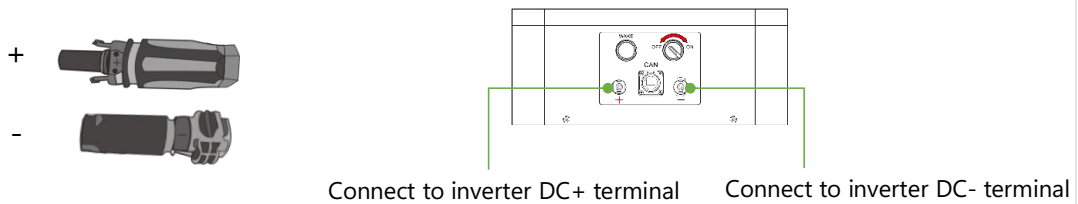

2. Connect the EXT-CAN communication cable to the inverter.
3. Connect the EXT-CAN communication cable to the inverter RJ45 CAN port.

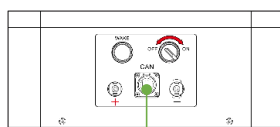

Connect to inverter RJ45 CAN communication port

CAUTION

A external DC Breaker that operates both positive and negative conductors simultaneously between the BDU and inverter on the power cable is recommended. After waking up the BDU and ensure that the BDU is pre-charged, it can be turned on.

4 Maintenance

Trouble Shooting



DANGER

The battery system is high voltage DC system. Must make sure that the grounding surface of the Tower is stable and reliable.

Please confirm that the battery system is in off state before connecting. It might cause electric shock to personnel and damage to the inverter if the battery is connected with inverter directly without powering off.

Otherwise, the system cannot working properly. The voltage of the battery is too high, please pay attention to self-protection during the measurement.

No	Problem	Possible Reason	Solution
1	The battery has no voltage output, and "POWER ON"/"POWER WAKE" Light is off.	The DC breaker of the BDU is not turned on	Turn on the DC breaker of BDU
		The "POWER ON" switch of the BDU box is not switched on	Switch on the "POWER ON" button
		Battery is in sleep state.	Long press the "POWER WAKE" button for about 5secs
		The fuse in the BDU box is faulty	Replace fuse
2	The battery has no voltage output, but "POWER ON"/"POWER WAKE" is on	Battery gets into over-discharged protection	Charge the battery to relieve the protection state
		The relay in BDU is faulty	Replace a new BDU directly
3	When the battery is connected to the inverter, the DC breaker trips automatically	The circuit between the battery and the inverter has a short circuit point	Check whether there is a short circuit in the circuit between the battery and the inverter; Check if the inverter is faulty
4	Communication failure between battery and inverter	The wrong battery model type is selected in the inverter's setting	Select correct battery model type in the inverter's setting

Replacement of Main Component

Replacement of Battery Controller (BDU)

 **WARNING**

Turn off the whole battery system. Ensure that the Negative terminal and Positive terminal have no power.

1. Switch off the "POWER ON" switch.

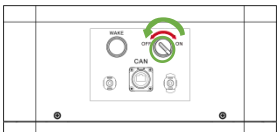

2. Switch the BDU "DC BREAKER" to the "OFF" state .

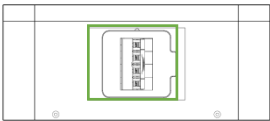

- Unplug the connection cable
- Remove the four screws on the BDU and remove the BDU from the system.

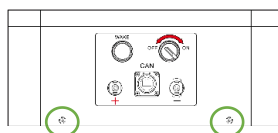



Figure 4-1 BDU right interface

- Change a new BDU. Then fix it with four screws.
- After replacing the new BDU, the battery self-test needs to be performed again. (Refer to P20 Table 3-2 Battery system self-test)

Battery Maintenance

 **DANGER**

The maintenance of battery only can be operated by professional and authorized person.

You need turn off the battery system firstly when you do some maintenance items.

Voltage Inspection:

[Periodical Maintenance] Check the voltage of battery system through the monitoring software. Check whether the system voltage is normal or not. For example: Check whether single cell' voltage is out of rated range.

Voltage Inspection:

[Periodical Maintenance] Check the SOC of battery system through the monitoring software. Check whether the SOC of battery string is normal or not.

Cables Inspection:

[Periodical Maintenance] Visually inspect all the cables of battery system. Check whether the cables have been broken, aging and loose or not.

Balancing:

[Periodical Maintenance] The battery system will become unbalanced if has not been charged fully for a long time. Solution: Preform the balancing maintenance (fully charged) every 3 month. Generally this maintenance progress needs to be completed when external devices such as the monitoring software and battery and inverter are in good communication.

Output Relay Inspection:

[Periodical Maintenance] Under low load condition (low current), control the output relay OFF and ON to hear whether the relay has click voice, which means that this relay can off and on normally.

5 Storage Recommendations

For long-term storage (more than 3 months), the battery cells should be stored in the environment: temperature range of 5~45°C, relative humidity <65% and contains non-corrosive gas.

The battery module should be placed in range of 5~45°C, dry, clean and well ventilated environment. The battery should be charged to 50~55% SOC before storage.

It is recommended to activate the battery system (discharge and charge) every 3 months, and the longest duration of storage without charge and discharge cannot exceed 6 months.



CAUTION

The cycle life of the battery will have relative heavy reduction if not follow the above instructions to store the battery for a long term.

6 Shipment

Battery module will be pre-charged to 50% SOC or according to customer requirement before shipment. The remaining capacity of battery cell is determined by the storage time and condition after shipment.

The battery modules meet the UN38.3 certificate standard.

In particular, special rules for the carriage of goods on the road and the current dangerous goods law, especially ADR (European Convention on the International Carriage of Dangerous Goods by Road), as amended, must be observed.

DYNNESS

DISCOVER YOUR NATURE

Address: No. 511 Chenzhuang West Road, Sanshui Street,
Jiangyan District, Taizhou City

Email: service@dyness.com

Tel: +86 400 666 0655

Web: www.dyness.com



Official Website



Digital version access