

Solar Stand Layout Drawing - 2 Panels Extensions

Stand Layout Drawing

Stand And Panel Layout Top View

Detail 1: Base Plate Fixings

- a) Back Fixing
- b) Side Fixing

Detail 2: Purlin Fixing

Detail 3: Purlin Assembly

Detail 4: Slotted "L" Plate Fixing

- a) Using Panel Mounting Holes
- b) Using Mid And End Clamps

Detail 5: Cross Bracing Fitting

Detail 6: Fixing Panel To Structure

- a) Using Panel Mounting Holes
- b) Using Mid and End Clamps

Anex 1: Leg Assembly (Drawings)

Stand Layout Drawing - 2 Panels

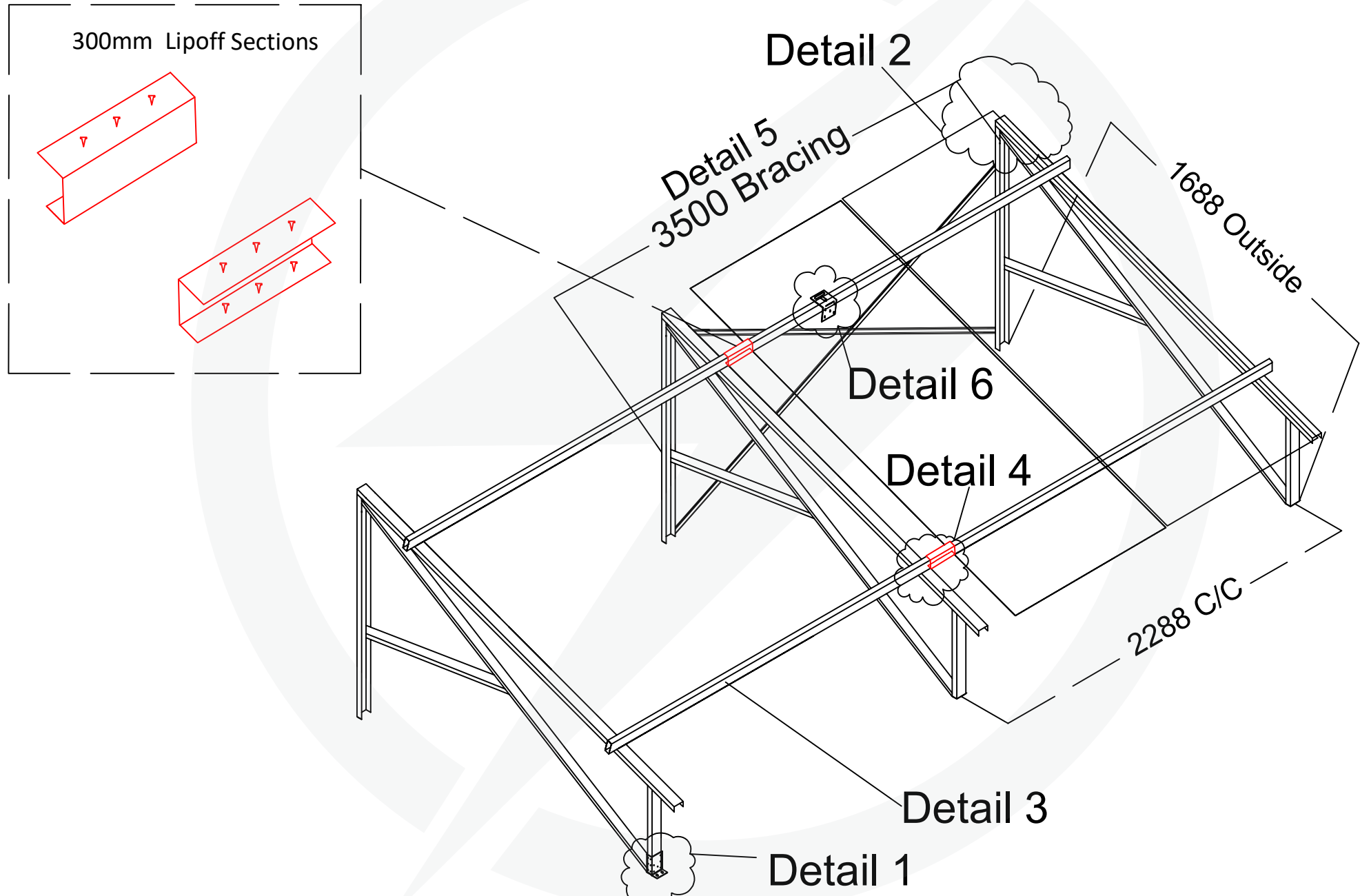

Stand and Panel Layout - Top View

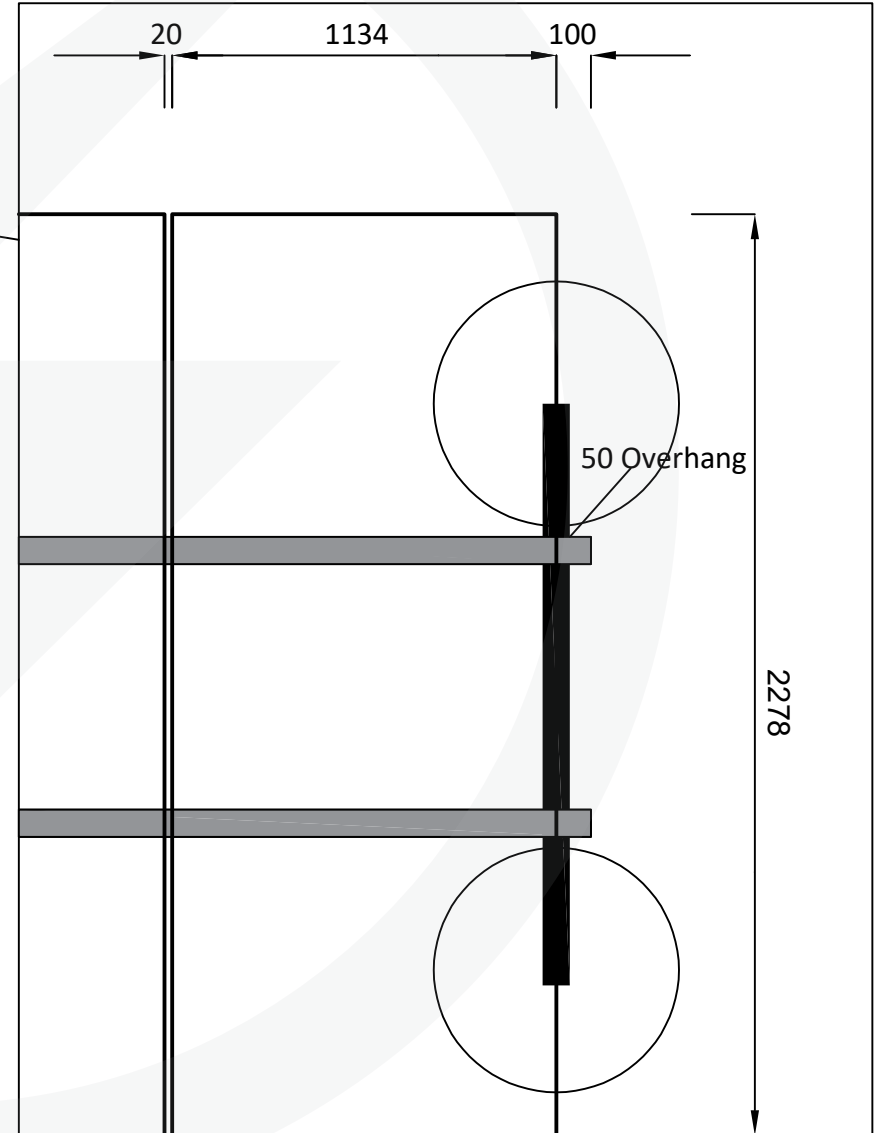
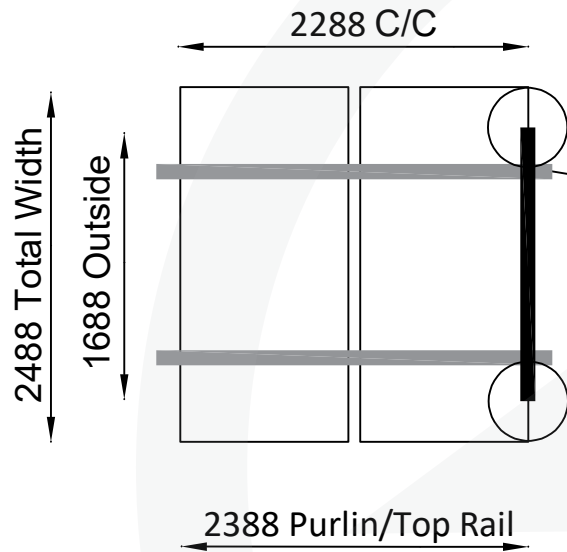

Pile Square Calculations

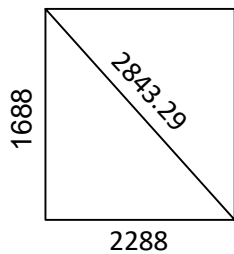

Detail 1: Base Plate Fixings

Detail 2: Purlin Fixing PvPOWER.CO.ZA Everything Solar

a) Back Fixing

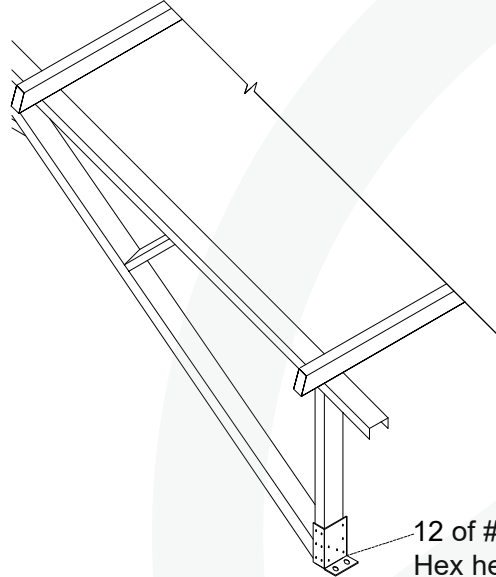

12 of #12- 14x20mm Zap
Hex head Self-Drilling
Screw - 6 of in each
plane

b) Side Fixing

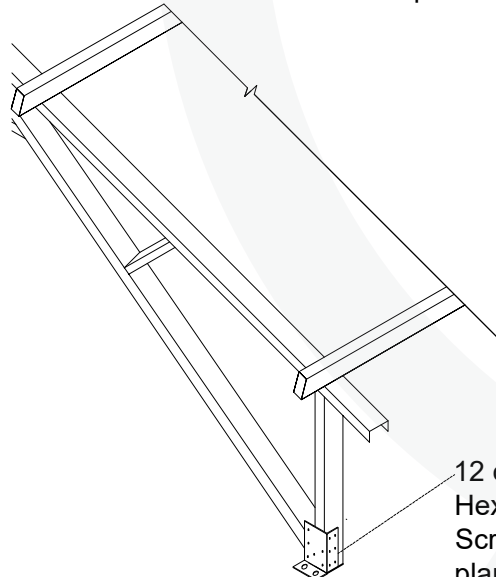

12 of #12- 14x20mm Zap
Hex head Self-Drilling
Screw - 6 of in each
plane

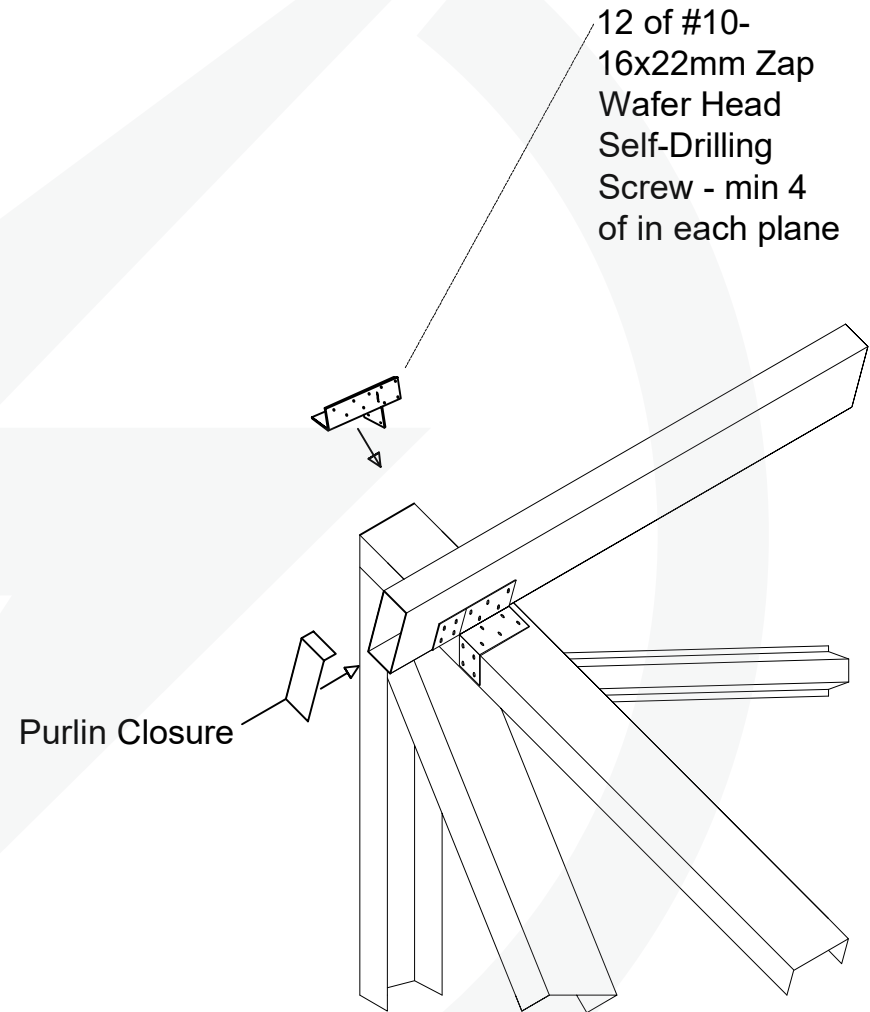

Detail 3: Purlin Boxing Assembly

Purlin 1 - 2.288 (Marked as P1; 1-4)

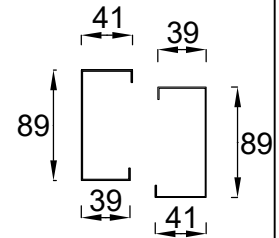
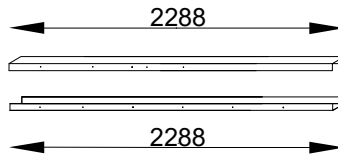

Boxing to be screwed together with #10- 16x22mm Zap Wafer Head Self-Drilling Screw every 300mm on both sides

Boxing to be screwed together with #10- 16x22mm Zap Wafer Head Self-Drilling Screw every 300mm on both sides



Detail 4: Slotted "L" Plate Fixing

a) Using Panel Mounting

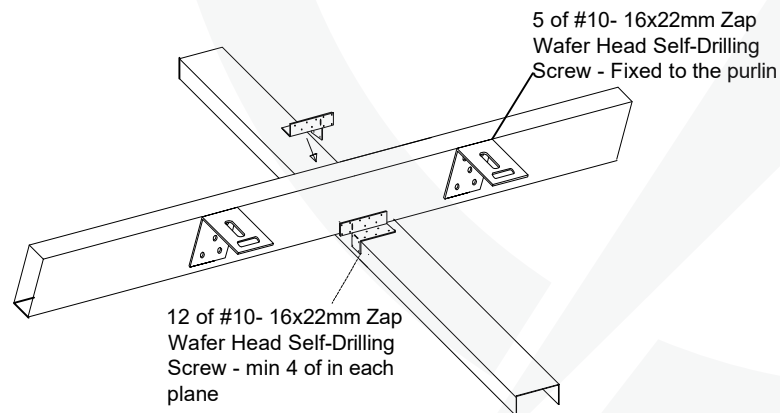

b) Using Mid And End Clamps

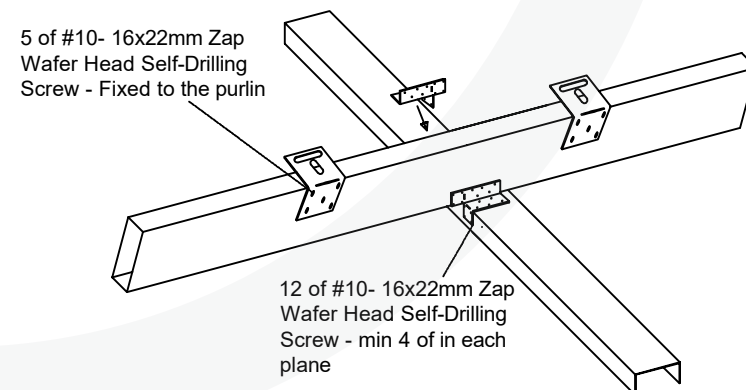

Detail 5: Cross Bracing Fitting

Bracing (Marked as B1; 1-2)

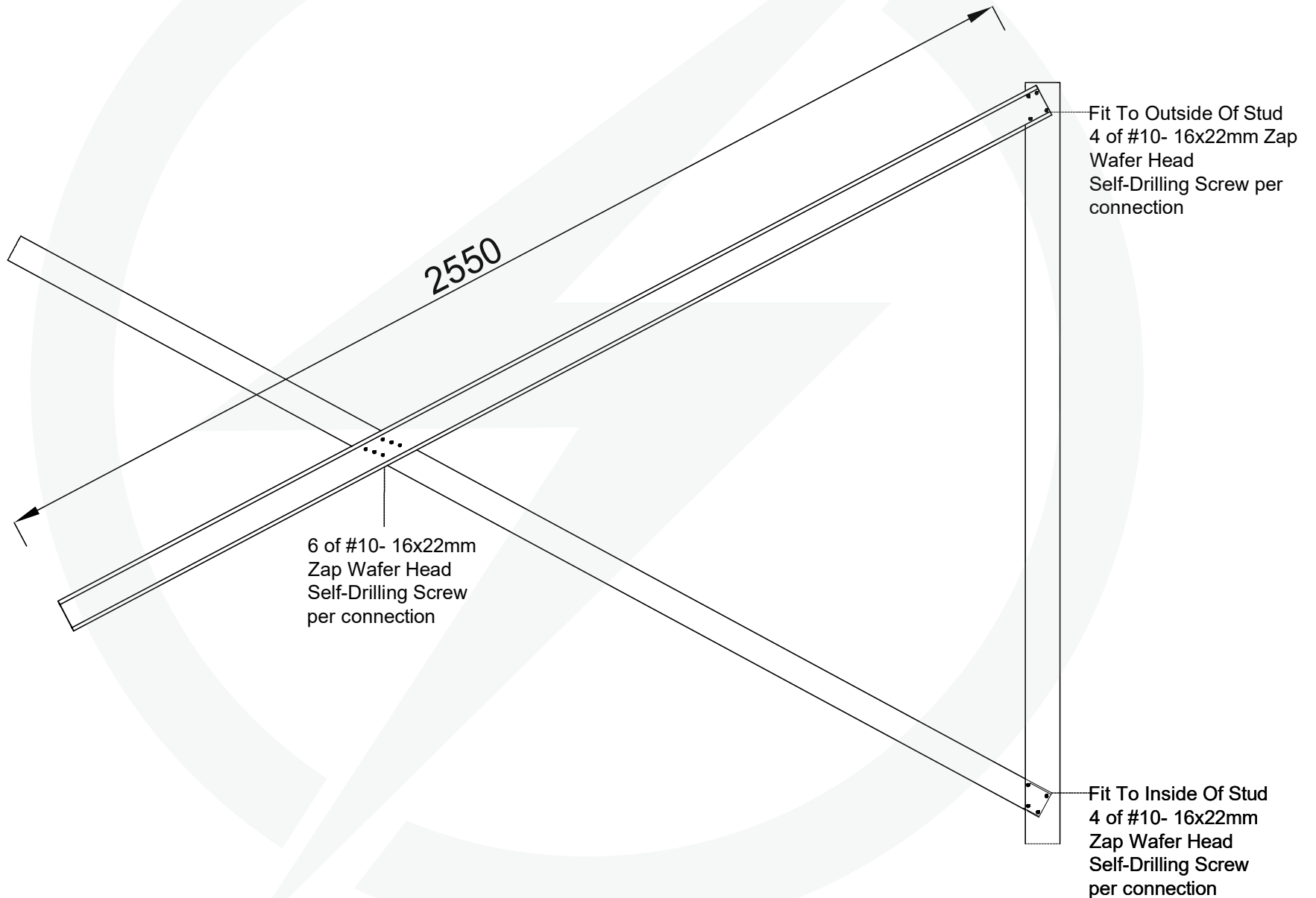

Detail 6: Fixing Panel To Structure

a) Using Panel Mounting

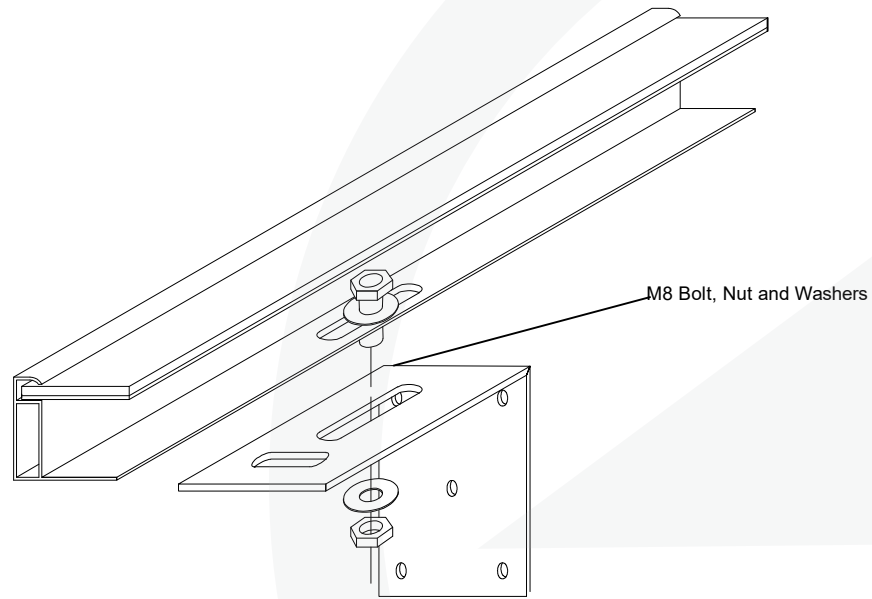

b) Using Mid And End Clamps

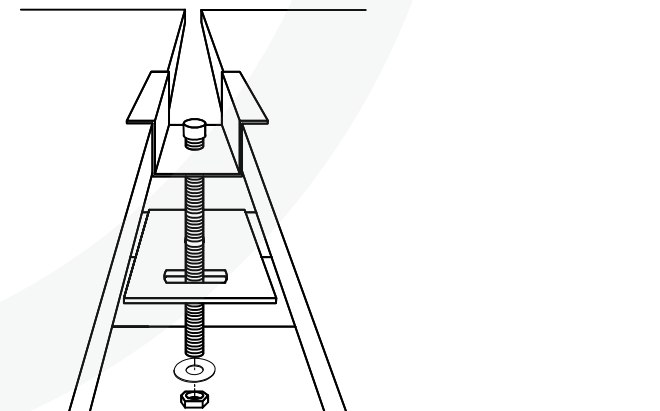
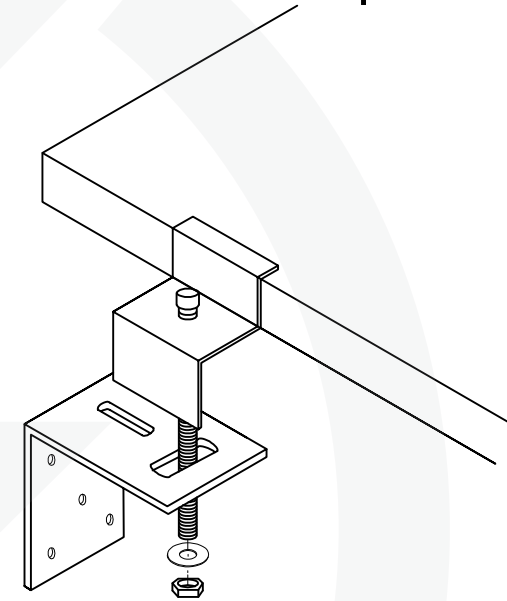

Total Length: 7.86 m Estimated Total Weight: 9.1 kg

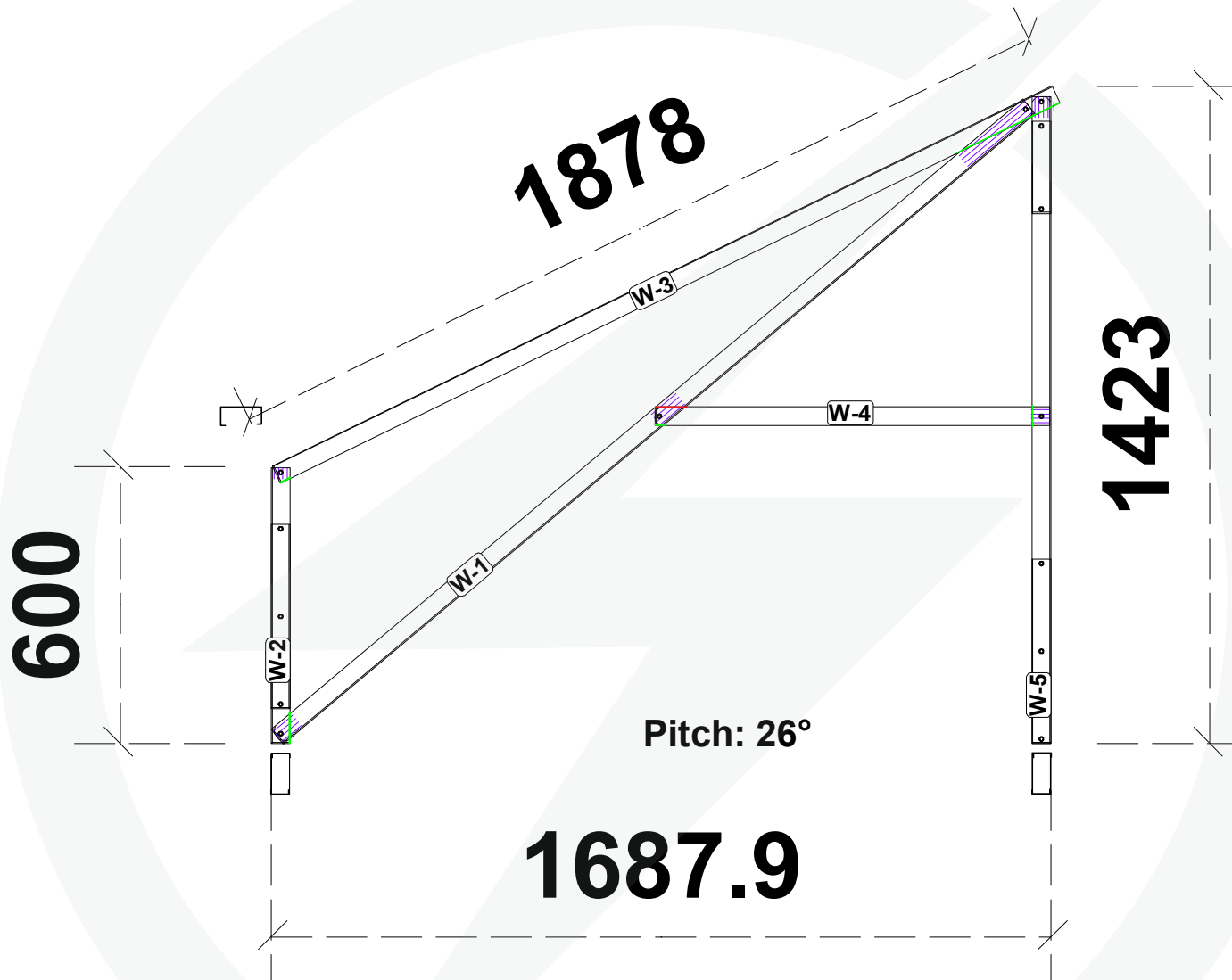

Powered by FRAMECAD Detaller ©

Single 26-File 3-F300	26 Truss - Tr1	
	JOB NUMBER:	
	DATE LAST SAVED: 28 October 2024	SCALE: Not to scale
	DRAWN:	REVISION:

Truss Leg Boxing

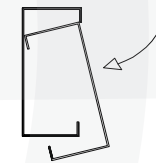
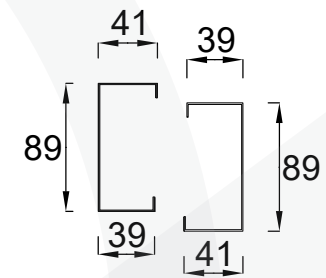
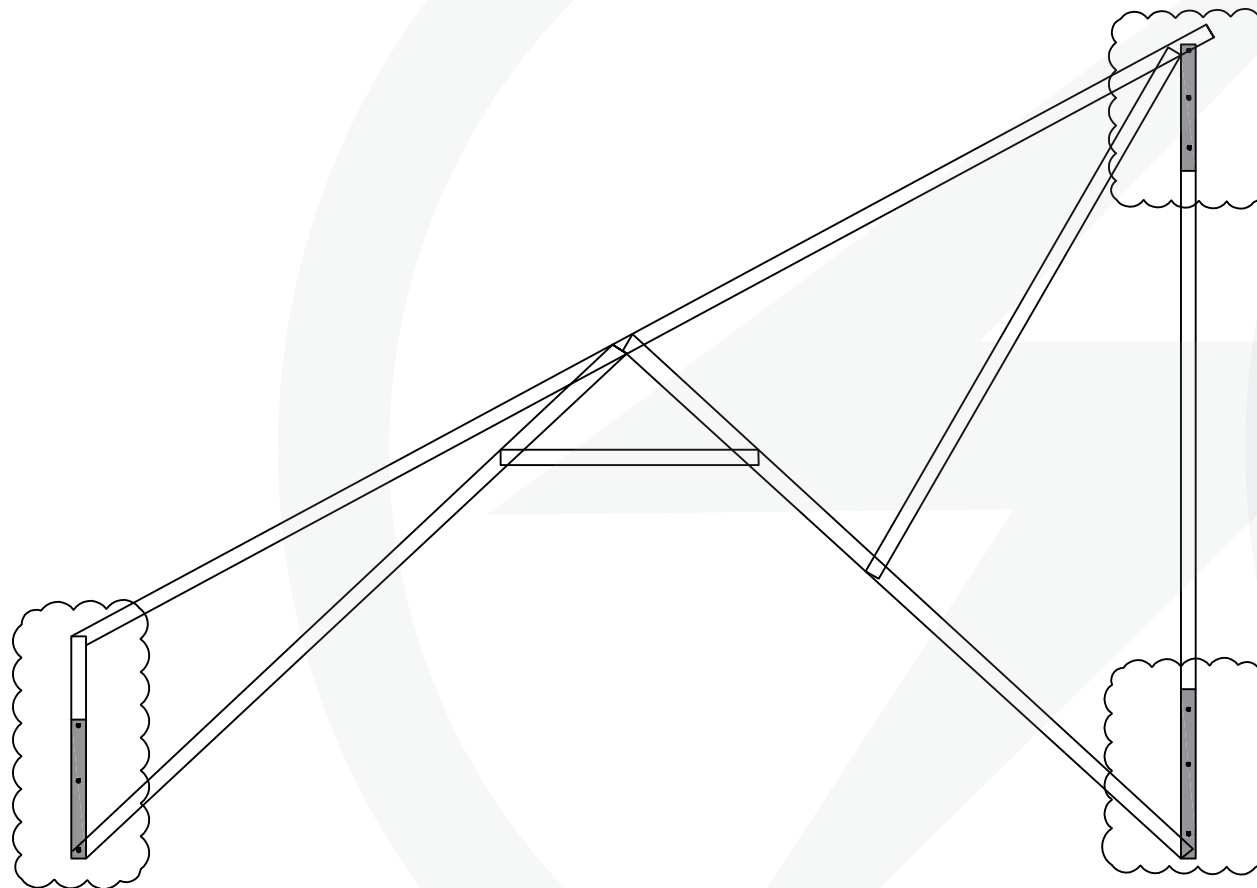

Boxing to be screwed together with #10- 16x22mm Zap Wafer Head Self-Drilling Screw every 300mm on both sides

Section Detail

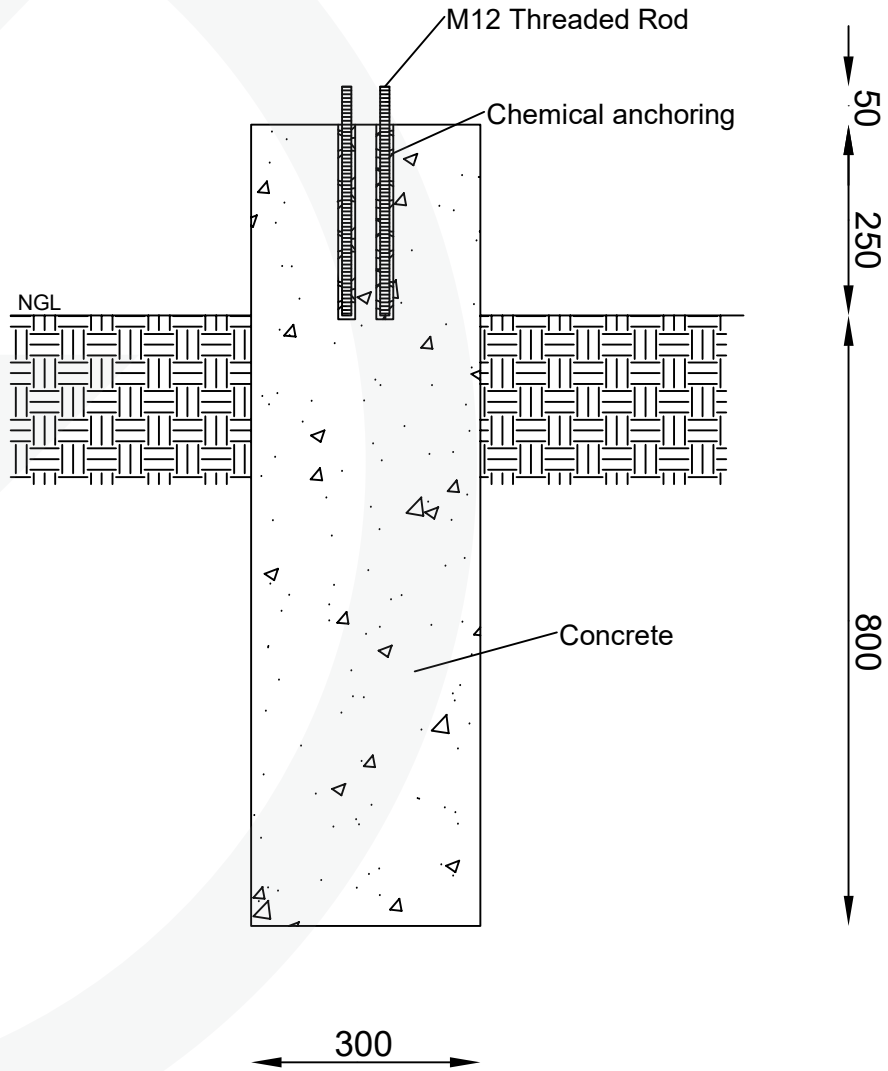

Top View

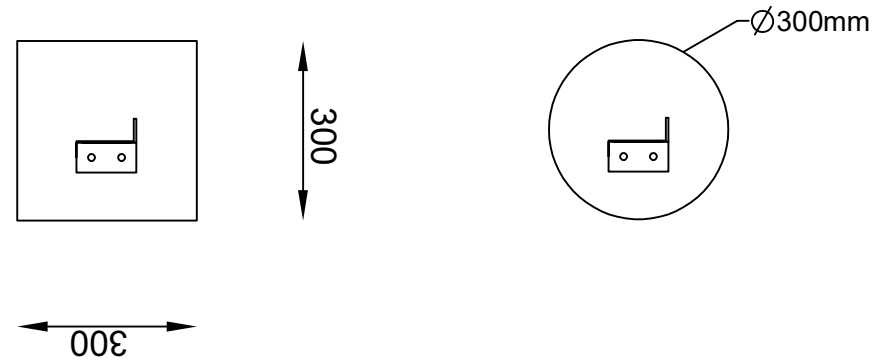

3D View

